

- NOTES:
- MATERIAL:
    - HOUSING: HALOGEN FREE PLASTIC, HIGH TEMP.,UL94V-0.
    - CONTACT: COPPER ALLOY
    - FITTING NAIL: COPPER ALLOY
  - FINISH:
    - CONTACT:
      - UNDERPLATING: 50u" NICKEL MIN OVERALL. FINISH:SEE ORDER INFORMATION.
    - FITTING NAIL:
      - UNDERPLATING: 50u" NICKEL MIN OVERALL. FINISH:SEE ORDER INFORMATION.
  - REFLOW SOLDER CAPABLE TO 260°C PER ACES SPEC.
  - SPEC. PLS. REFER TO PS-50273-xxxx-xxx
  - PACKAGE PLS. SEE P/N LEGEND
  - APPLY EVEN CIRCUIT PRODUCTS.
  - LOCKING WINDOW:ONE PLACE FOR 2&3 CKTS. TWO PLACES FOR MORE THAN 4 CKTS.

☒ RESTRICTION AREA WITHOUT ELECTRIC LINE  
 RECOMMENDED P.C.BOARD PATTERN DIM.(REF)

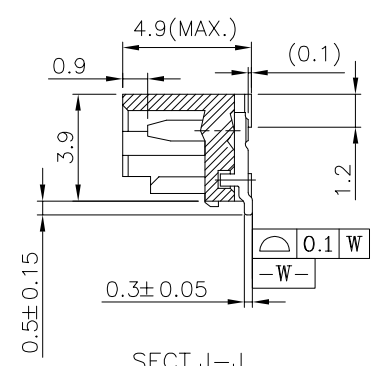
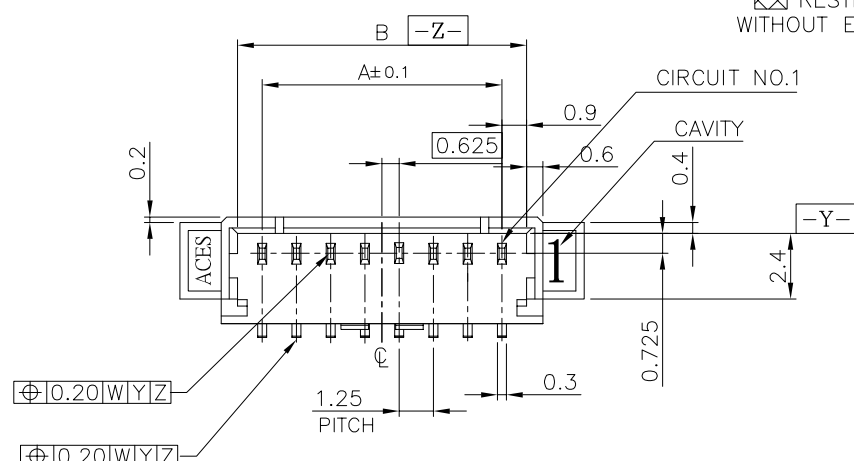

P/N LEGEND

51289-XXX	X	X-XXX	XXX	Material&Color	PACKING
NO OF CKT			002	HF&NATURAL	51289-xxxx-xx-TRP ( With Cover)
PACKING			003	HF&NATURAL	51289-xxxxx-U-TRP ( With Cover)
0:TAPE & REEL					PLATING
1:TUBE PACKAGE					1:GOLD FLASH
7:TAPE & REEL WITH COVER					N:MATT TIN

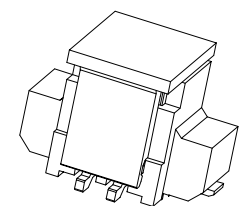
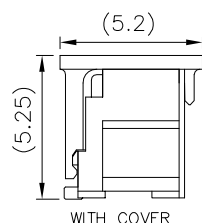
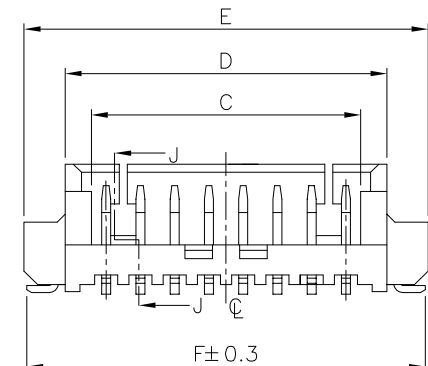

CKT	Dim A	Dim B	Dim C	Dim D	Dim E	Dim F
4	3.75	5.55	4.85	6.75	9.75	9.65
8	8.75	10.55	9.85	11.75	14.75	14.65

QUALITY SYMBOLS	DRAWN BY	DATE	
MAJOR Ⓢ	GUOFEI	23/10/19	
CRITICAL Ⓢ	CHECKED BY	DATE	<b>TITLE</b> 1.25mm S/T WIRE TO BOARD SMT TYPE
GENERAL TOLERANCES (UNLESS SPECIFIED)	XUZHUYONG	23/10/19	
X. ±0.5	APPROVED BY	DATE	UNITS  SIZE A4 RFO NO. SCALE 5 : 1 SHEET NO. 1 OF 1 REV C DWG NO. 51289-XXXXX-XXX
.X ±0.25	XUZHUYONG	23/10/19	
.XX ±0.15			
.XXX ±0.1			
ANGLES ±2°			